

User Manual

Residential High-voltage Lithium Battery BHF-S Series

v1.0 2025-07

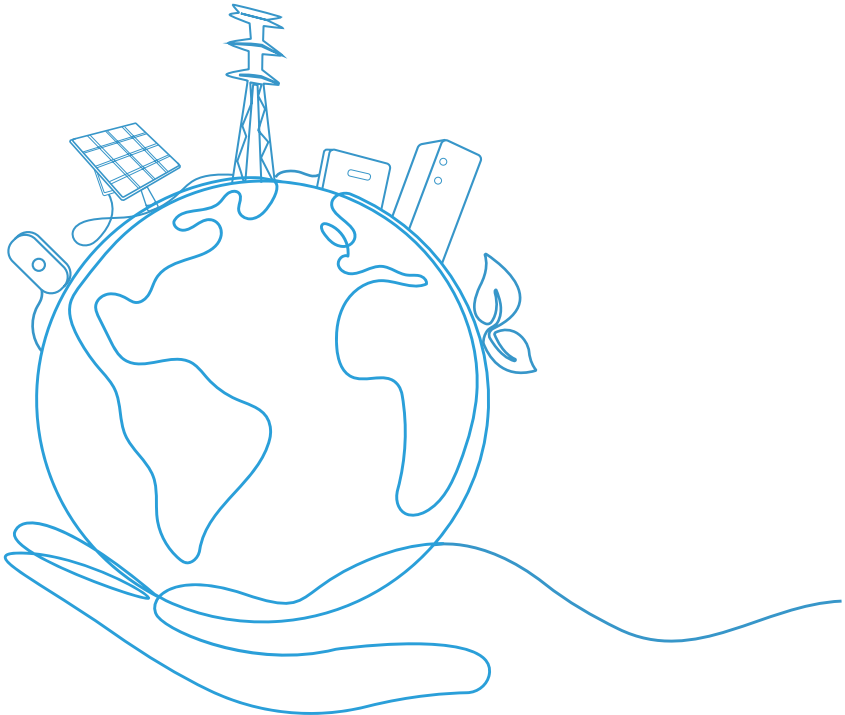

Legal Provisions

Copyright © Hangzhou Livoltek Power Co., Ltd. 2025 All rights reserved.

The information contained in these documents is the property of Hangzhou Livoltek Power Co., Ltd. No part of this document may be reproduced, stored in a retrieval system, or transmitted, in any form or by any means, be it electronic, mechanical, photographic, magnetic or otherwise, without the prior written permission of Hangzhou Livoltek Power Co., Ltd. Internal reproduction used solely for the purpose of product evaluation or other proper use is allowed and does not require prior approval.

Warranty

You can download the current warranty conditions from the Internet at www.livoltek.com.

Trademarks

LIVOLTEK and other Livoltek trademarks are trademarks of Hangzhou Livoltek Power Co., Ltd. All other trademarks and trade names mentioned in this document are the property of their respective holders.

Notice

Hangzhou Livoltek Power Co., Ltd. makes no representations or warranties, express or implied, with respect to this documentation or any of the equipment and/or software it may describe, including (with no limitation) any implied warranties of utility, merchantability, or fitness for any particular purpose. All such representations or warranties are expressly disclaimed. Neither Hangzhou Livoltek Power Co., Ltd. nor its distributors or dealers shall be liable for any indirect, incidental, or consequential damages under any circumstances.

The exclusion of implied warranties may not apply in all cases under some statutes, and thus the above exclusion may not apply.

Specifications are subject to change without notice. Every attempt has been made to make this document complete, accurate and up-to-date. Readers are cautioned, however, that product improvements and field usage experience may cause Hangzhou Livoltek Power Co., Ltd. to make changes to these specifications without advance notice or per contract provisions. Hangzhou Livoltek Power Co., Ltd. shall not be responsible for any damages, including indirect, incidental or consequential damages, caused by reliance on the material presented, including, but not limited to, omissions, typographical errors, arithmetical errors or listing errors in the content material.

About the Manual

Validity

This manual is valid for the following products:

- BHF-S10
- BHF-S15
- BHF-S20
- BHF-S25
- BHF-S30

Model Description

BHF - S 10

1 2 3

No.	Item	Description
1	Product Name	"B" refers Battery, "H" is High-voltage, "F" is LFP.
2	Series Name	"S" refers Small High-voltage Battery product.
3	Total Energy	Total energy of 10 kWh. Energy range: 10 ~ 30.





Target Group

This document is intended for qualified persons and operators. Only qualified persons are allowed to perform the activities marked in this document with a warning symbol and the caption "Qualified person". Tasks that do not require any particular qualification are not marked and can also be performed by operators. Qualified persons must have the following skills:

- Have basic knowledge and installation skills of the product.
- Training to deal with risks associated with installing, repairing, and using electrical devices, and batteries.
- Training in the installation and commissioning of electrical devices and installations.
- Knowledge of all applicable laws, regulations, standards, and directives.
- Knowledge of and compliance with this document and all safety information.
- Successful participation in a training course on commissioning the device with the Livoltek manufacturer.

Levels of Warning Messages

The following levels of warning messages may occur when handling the product.

 DANGER	Indicates risk of Electric Shock which will result in death or serious injury if not avoided.
 WARNING	Indicates a situation of moderate potential hazard that could result in death or serious injury if not avoided.
 CAUTION	Indicates a low level of potential hazard that, if not avoided, could result in moderate or minor injury to personnel.
 NOTE	Emphasis and additions to the content may also provide tips for optimizing the use of the product.

Release Note

Version	Version Update Record	Date
1.0	Initial release.	2025-07-25

Table of Contents

1	Safety	1
1.1	Safety Precaution	1
1.2	Response to Emergency Situations	2
1.2.1	Leaking Batteries	2
1.2.2	Wet Batteries or Damaged Batteries	2
1.2.3	Fire	2
1.2.4	Advice for Firefighters	2
1.3	Handling and Storage Precautions	3
1.4	Limitation of Liability	3
1.5	Symbols on the Label	4
2	Product Overview	5
2.1	Appearance	5
2.2	Product Sizes	6
2.3	Overview of Connection Area	7
3	Installation Preparations	8
3.1	Tools Preparations	8
3.1.1	Tools Requirements	8
3.2	Installation Site Condition	8
3.2.1	Environment	8
3.2.2	Angle and Space Requirements	9
4	Unpacking and Inspection	11
4.1	Unpacking	11
4.2	Scope of Delivery	11
5	Mechanical Mounting	14
5.1	Pre-installation Check	14
5.2	Installation Procedure	14
5.2.1	Install Three Packs	14
5.2.2	Install More Packs	17

6	Electrical Connection	18
6.1	Battery Connection	18
6.2	BMS Communication Connection	19
7	Operation	20
7.1	LED Indicator	20
7.2	Turn On/Off the Battery	20
7.3	Commissioning Procedure	20
7.4	Decommission	20
8	Technical Specifications	21

1 Safety

1.1 Safety Precaution

The manual describes the installation, commissioning, maintenance of the battery. Please read it carefully before operating. To prevent personal injury and property damage and to ensure long-term operation of the product, please read and follow all the instructions and cautions on the battery and in this user manual during installation, operation or maintenance at all times.



DANGER

Danger to life from electric shock.

- Before performing any work on the battery, make sure the battery is power off and the DC isolator is disconnected.
- Do not short connect the DC connectors of the battery, which may cause electric shock to personnel and damage to the product.
- Do not touch DC connectors of the battery.
- If an error occurs, contact your local distributor or qualified electricians.



WARNING

- Only authorized personnel are allowed to install the battery or perform servicing and maintenance.
- The power should be disconnected before attempting any maintenance or cleaning or working to the battery.



NOTE

- Do not open the battery or change any components without authorization.
- Appropriate methods must be adopted to protect battery from electrostatic discharge (ESD), any damage caused by ESD is not warranted by the manufacturer.

1.2 Response to Emergency Situations

1.2.1 Leaking Batteries

If the battery leaks electrolyte which is corrosive, avoid contact with the leaking liquid or gas. Direct exposure to the liquid or gas may lead to skin irritation or chemical burns. If one is exposed to the leaked substance, do these actions:

- **General Advice:** Immediate medical attention is required. Show the safety data sheet (SDS) to the doctor in attendance.
- **Eye Contact:** Rinse thoroughly with plenty of water for at least 15 minutes and consult a physician if feel uncomfortable.
- **Skin Contact:** Take off contaminated clothing and shoes immediately. Wash off with plenty of water for at least 15 minutes and consult a physician if feel uncomfortable.
- **Ingestion:** Do not induce vomiting. Never give anything by mouth to an unconscious person. Call a physician or Poison Control Center immediately.
- **Inhalation:** Move victim into fresh air. If breathing is difficult, give oxygen. Do not use mouth to mouth resuscitation if victim ingested or inhaled the substance. If not breathing, give artificial respiration and consult a physician immediately.
- **Protecting of First-aiders:** Ensure that medical personnel are aware of the substance involved. Take precautions to protect themselves and prevent spread of contamination.

1.2.2 Wet Batteries or Damaged Batteries

- If the battery is wet or submerged in water, do not try to access it.
- If the battery seems to be damaged, they are not fit for use and may pose a danger to people or properties.
- Please pack the battery in its original container, and then return it to your distributor.

1.2.3 Fire

The battery may catch fire when it is put into fire. In case of a fire, please make sure that a dry chemical, carbon dioxide or alcohol-resistant foam extinguisher is nearby. Do not use a solid water stream as it may scatter or spread fire.

1.2.4 Advice for Firefighters

- In any fire, wear self-contained breathing apparatus (MSHA/NIOSH approved or equivalent) and full protective gear.
- Fight fire from a safe distance, with adequate cover.
- Prevent fire extinguishing water from contaminating surface water or the ground water system.

1.3 Handling and Storage Precautions









- Handling is performed in a well-ventilated place.
- Wear suitable protective equipment.
- Avoid contact with skin and eyes.
- Keep away from heat/sparks/open flames/ hot surfaces.
- Take precautionary measures against static discharges.
- Keep containers tightly closed.
- Keep containers in a dry, cool and well-ventilated place.
- Keep away from heat/sparks/open flames/ hot surfaces.
- Store away from incompatible materials and foodstuff containers.

1.4 Limitation of Liability

Any product damage or property loss caused by the following conditions Livoltek does not assume any direct or indirect liability.

- Product modified, design changed or parts replaced without Livoltek authorization;
- Changes, or attempted repairs and erasing of series number or seals by non Livoltek technician;
- System design and installation are not in compliance with standards and regulations;
- Failure to comply with the local safety regulations;
- The product has been improperly stored in distributor's or end user's premises;
- Transport damage (including painting scratch caused by movement inside packaging during shipping). A claim should be made directly to shipping or insurance company as soon as the container/packaging is unloaded and such damage is identified;
- Failure to follow any/all of the user manual, the installation guide and the maintenance regulations;
- Improper use or misuse of the device;
- Insufficient ventilation of the device;
- The maintenance procedures relating to the product have not been followed to an acceptable standard;
- Force majeure (violent or stormy weather, lightning, overvoltage, fire etc.)
- Damages caused by any external factors.

1.5 Symbols on the Label

Item	Description
	<p>Follow the instruction in this manual for service and replacement.</p>
	<p>CE Mark.</p>
	<p>Warning: General warning sign</p>
	<p>Caution: Risk of Electric Shock Disconnect all incoming power and turn off the product before working on it.</p>
	<p>Do not short circuit the battery.</p>
	<p>Keep the battery away from flame or ignition sources.</p>
	<p>Keep the battery away from children.</p>
 	<p>WEEE Mark. All electrical and electronic products should be disposed of separately from the municipal waste stream via designated collection facilities appointed by the government or the local authorities. The correct disposal of your old appliance will help prevent potential negative consequences for the environment and human health. For more detailed information about disposal of your old appliance, please contact your city office, waste disposal service or the shop where you purchased the product.</p>

2 Product Overview

The BHF-S Series battery is a series of High Voltage Lithium-ion battery. It is designed for residential and commercial energy storage system. It must only be connected with an officially tested inverter.

2.1 Appearance

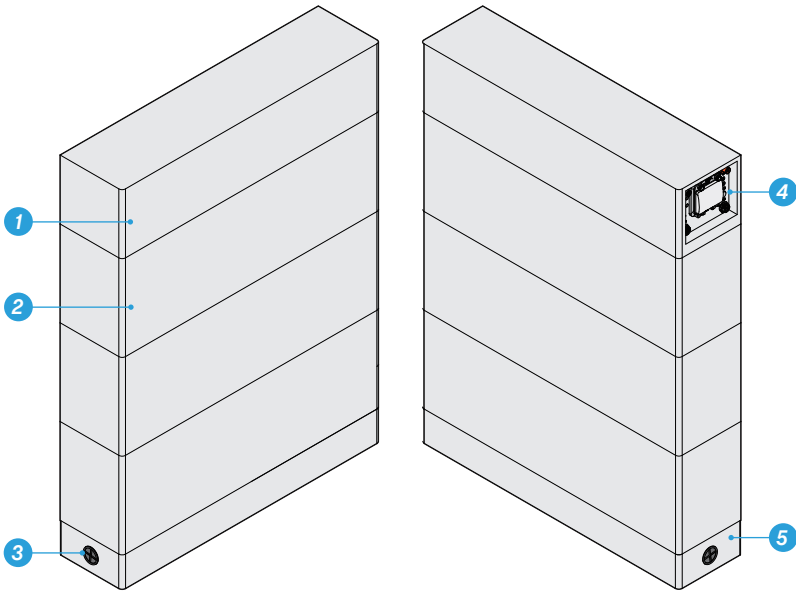

Figure 2-1 Appearance

Item	Name
1	Control box
2	Battery pack
3	Hole for Wire Connection
4	Connection Area
5	Mouting Base

2.2 Product Sizes

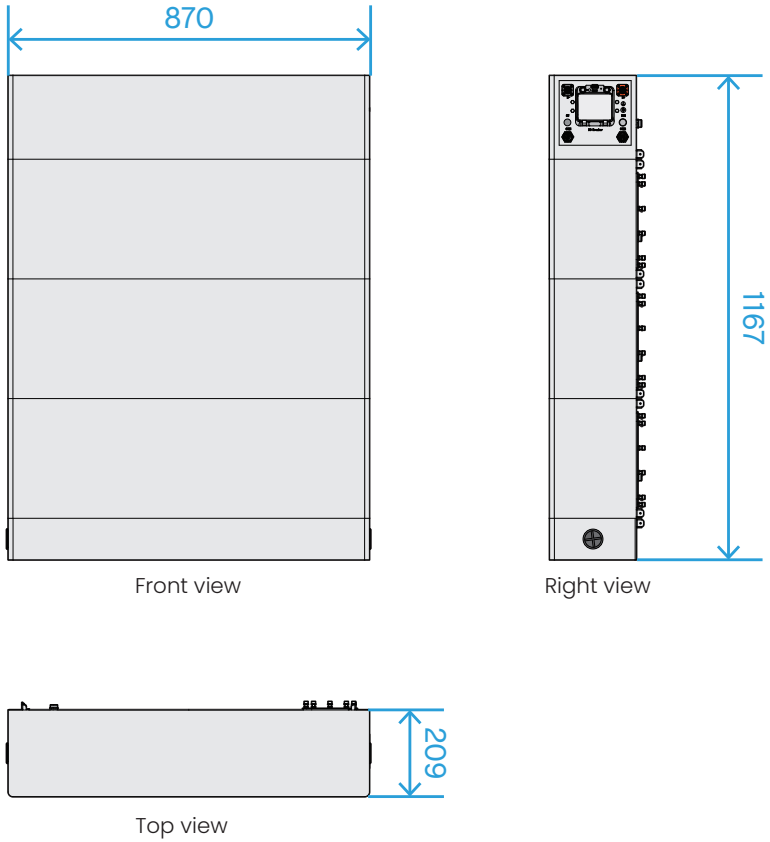

Figure 2-2 Product Size (Dimensions in mm)

2.3 Overview of Connection Area

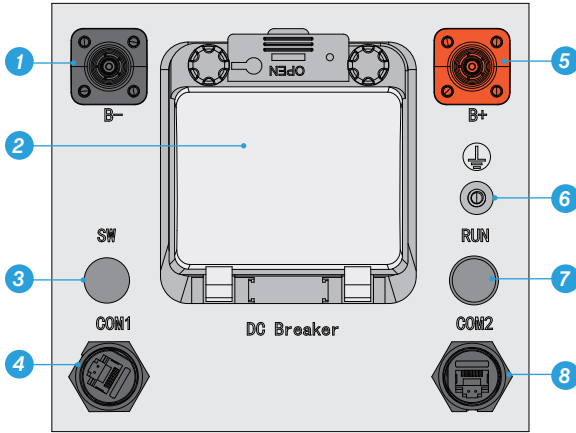

Figure 2-3 Connection Area of Control Box

Item	Name
1	Battery - terminal
2	DC Breaker
3	Power switch
4	Communication 1 connection area
5	Battery+ terminal
6	Ground Port
7	Status light
8	Communication 2 connection area

3 Installation Preparations

3.1 Tools Preparations

3.1.1 Tools Requirements

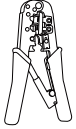

Wire crimper

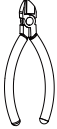

Diagonal pliers

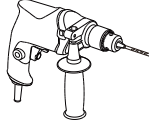

Pneumatic drill

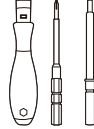

Cross screwdriver
Straight screwdriver



Torque wrench



Level



Pencil



Knife



Multimeter

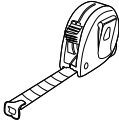

Tape measure



Insulated gloves



Safety goggles



Safety shoes

3.2 Installation Site Condition

3.2.1 Environment

Install the Battery System on the surface with sufficient bearing capacity and flatness, wooden surface is prohibited. Increase the bearing capacity and flatness of the surface by laying the foundation, adding bearing plates and so on.

- Keep children away from the battery.
- The optimal ambient temperature for the battery is 15 ~ 35 °C.
- Avoid exposing the equipment to direct sunlight or rain.
- Install the equipment away from heat/cold source.
- Do not install the equipment in the place where the temperature changes extremely.
- Install the equipment away from strong interferences to ensure its regular work.
- Do not install the equipment in places prone to accumulate water.
- Do not put inflammable or explosive matters near the equipment.

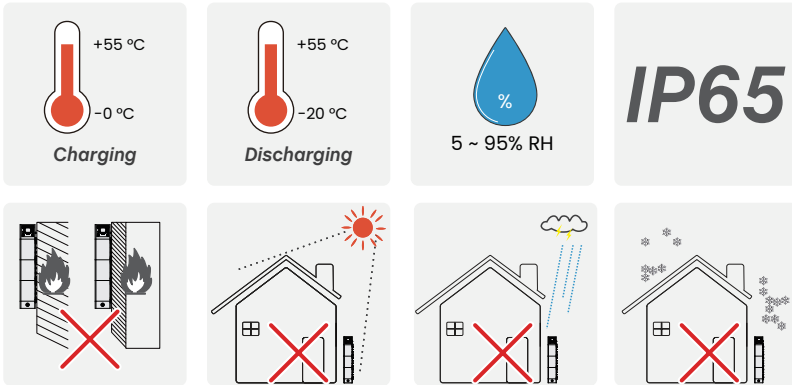

3.2.2 Angle and Space Requirements



CAUTION

- Never install the battery horizontally, or with a forward tilt or with a backward tilt or even with upside down. Install the battery upright or at a maximum back tilt of 15 degrees to facilitate heat dissipation.
- This battery is indoor version and can be only installed in an indoor location.

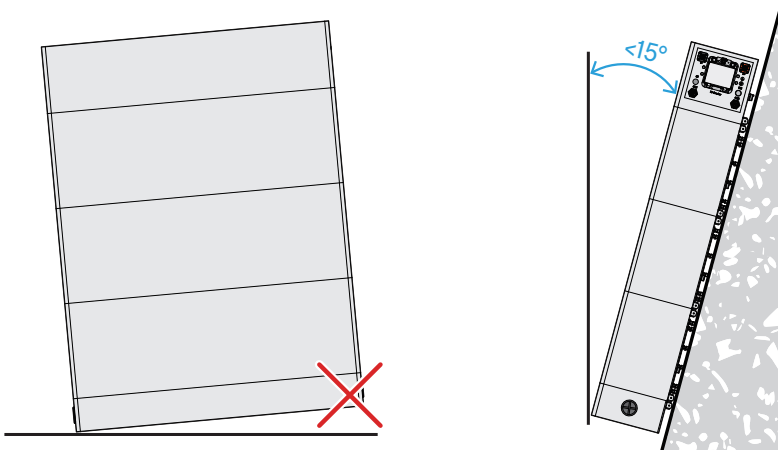

Figure 3-1 Angle Requirements

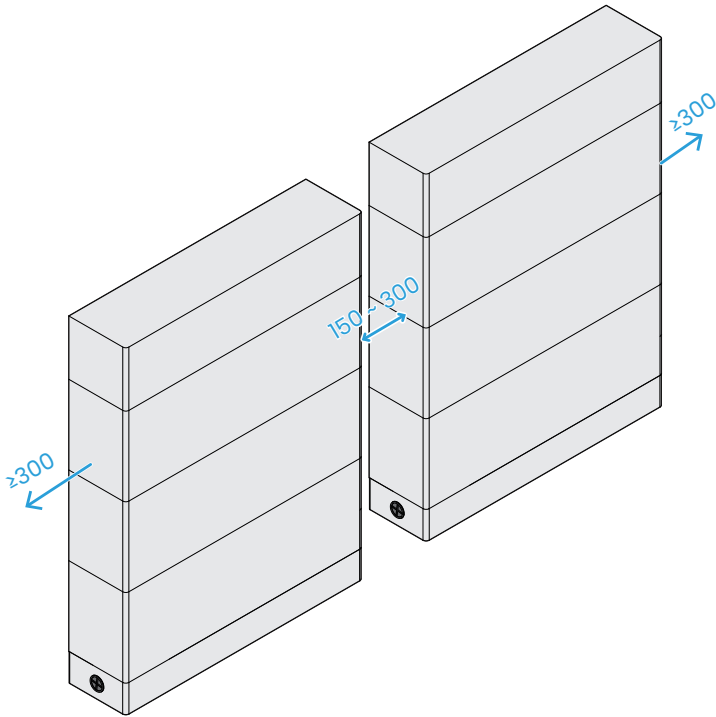

Figure 3-2 Space Requirement for Expansion (in mm)

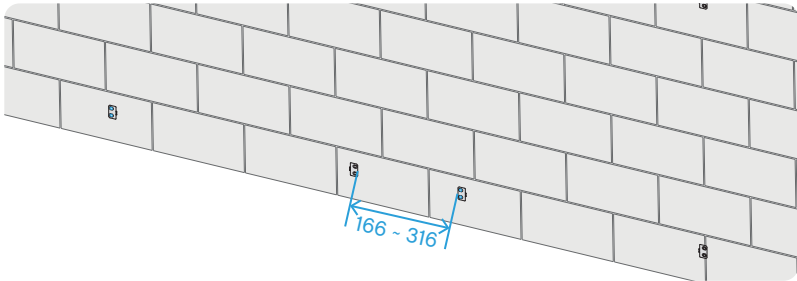

Figure 3-3 Space Between Two Brackets



CAUTION

- The horizontal space between two adjacent batteries should not exceed 300 mm.
- The horizontal space between two adjacent wall-mounted brackets should not exceed 316 mm, otherwise the length of parallel power cables will be insufficient.

4 Unpacking and Inspection

4.1 Unpacking

Unpacking the battery package and make sure the battery is intact during transportation. If there are some visible damages, such as cracks, or missing, please contact your dealer immediately.

4.2 Scope of Delivery

- Control Box & Mounting Base Subassembly

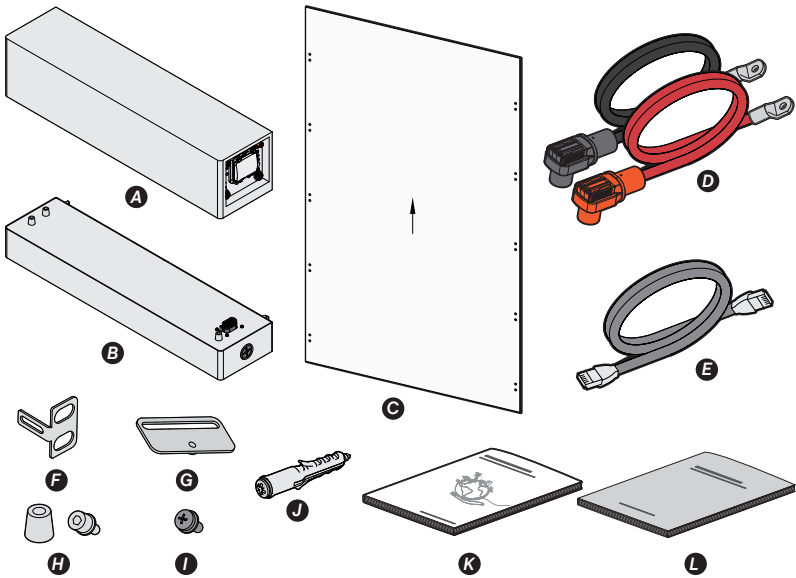

Figure 4-1 Scope of Delivery of Control Box

Table 4-1 Components Included in Scope of Delivery of Control Box

Item	Description	Quantity
A	Control Box	1 pc
B	Mounting Base	1 pc
C	Perforating Paper	1 pc
D	Power Cable	1 pair
E	Communication cable	1 pc

Item	Description	Quantity
F	Wall-Mounting Bracket C	4 pcs
G	Wall-Mounting Bracket B	4 pcs
H	Locating Pin	3 pcs
I	Bolts for Bracket	12 pcs
J	Expansion Anchor Bolts	8 pcs
K	User Manual	1 pc
L	Safety Data Sheet	1 pc

- Battery Subassembly

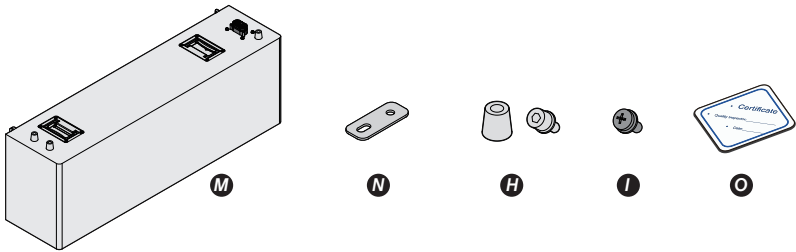

Figure 4-2 Scope of Delivery of Battery Pack

Table 4-2 Components Included in Scope of Delivery of Battery Pack

Item	Description	Quantity
M	Battery	1 pc
N	Wall-Mounting Bracket A	2 pcs
H	Locating Pin	3 pcs
I	Bolts for Bracket	4 pcs
O	Certificate	1 pc

- Subassembly of Tandem Optional Kit

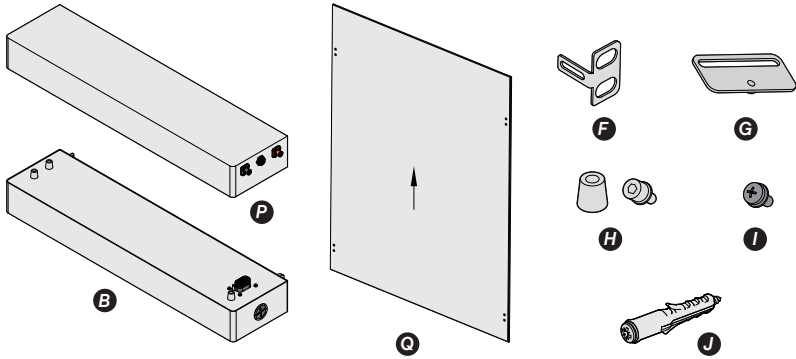

Figure 4-3 Scope of Delivery of Battery Pack

Table 4-3 Components Included in Scope of Delivery of Battery Pack

Item	Description	Quantity
P	Tandem Kit	1 pc
B	Mounting Base	1 pc
Q	Perforating Paper	1 pc
F	Wall-Mounting Bracket C	4 pcs
G	Wall-Mounting Bracket B	4 pcs
H	Locating Pin	3 pcs
I	Bolts for Bracket	12 pcs
J	Expansion Anchor Bolts	8 pcs

i **NOTE**

Accessories for different applications may be different.

5 Mechanical Mounting

⚠ QUALIFIED PERSON

5.1 Pre-installation Check

- After opening the package, check if the package items are complete. If there is any part missing, please contact your dealer immediately.
- Check and confirm the battery is power off and DC breaker is off before any further step.
- Turn on the DC breaker, when the battery self-test successfully, its green light turns on. If the red light is on, please contact your dealer immediately.
- Then go on to next step after turning off the battery.

5.2 Installation Procedure

5.2.1 Install Three Packs

Step 1: Make sure the wall is strong enough to withstand the weight of battery. Take out the perforating paper **C** and put the bottom of perforating paper parallel to the floor, then stick the perforating paper on the wall.

Step 2: Drill a certain number of holes with a $\varnothing 8$ drill bit, make sure the holes are deep enough (at least 65 mm) to support the battery.

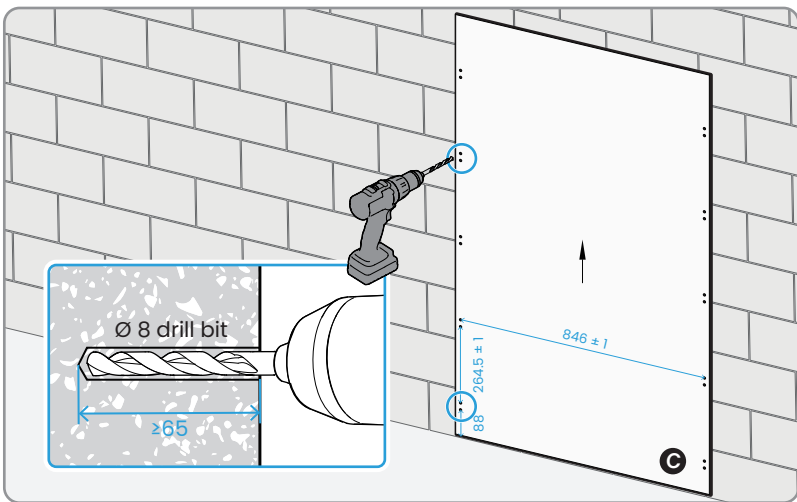

Figure 5-1 Drilling Holes

i **NOTE**

The following picture shows the scenario of installing 3 battery packs and drilling the holes, if 2 or 4 packs need to be installed, refer to the location marked in the picture below.

Step 3: Then take the perforating paper down after drilling.

Step 4: Align the Wall-Mounting Bracket **C** **F** to the hole first, then hammer the expansion anchor bolts **J** into the holes. Make sure Wall-Mounting Bracket is locked correctly according to shapes in perforating paper.

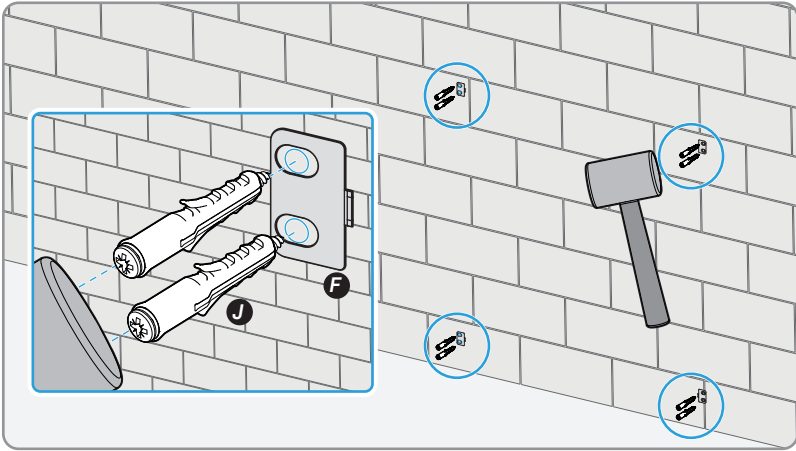

Figure 5-2 Hammering Expansion Bolts

Step 5: Screw the expansion bolts **J** clockwise tightly.

Step 6: Screw the Locating Pin **H** to the Battery **M** and Mounting Base **B**.

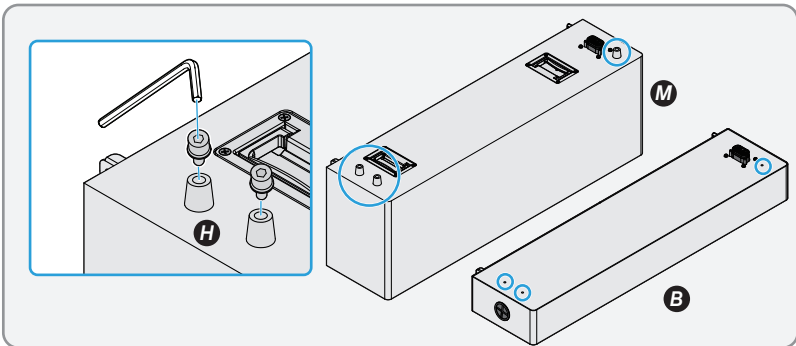

Figure 5-3 Screwing Locating Pin

Step 7: Connect Ground wire to the Mounting base **B** and ground firstly; Stack the

Mounting base **B**, Battery pack **M** and Control box **A** in turn.

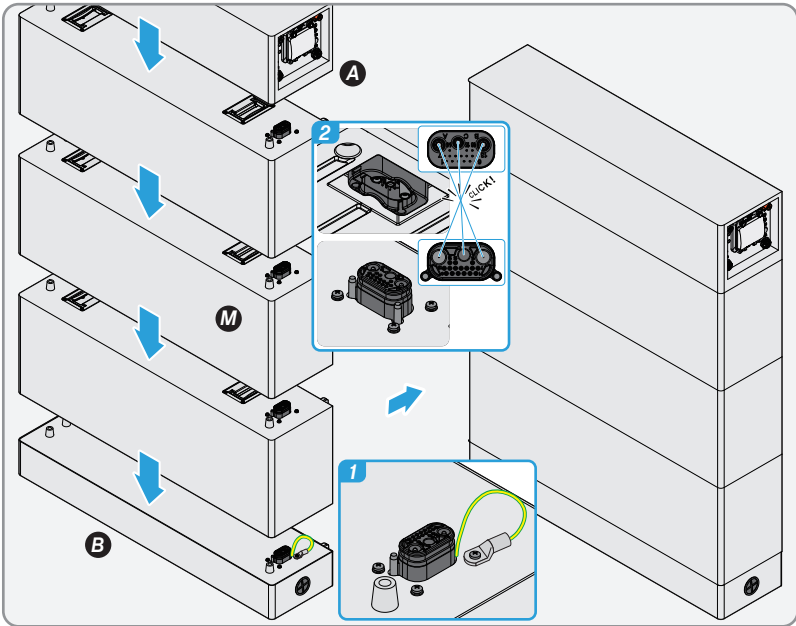

Figure 5-4 Stacking All Parts

Step 8: Lock the Bolts **I** between bracket A, B, C **N F G** and Battery referring to the picture below, make sure different part is locked tightly to each other.

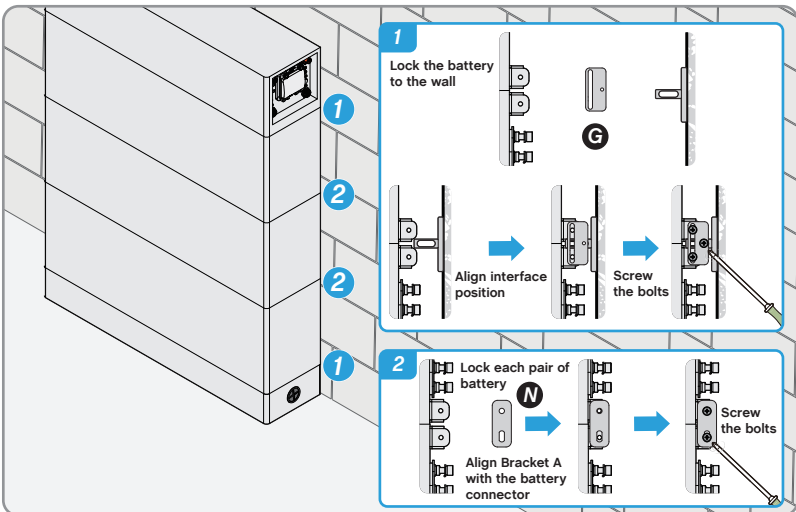

Figure 5-5 Mounting the Battery

5.2.2 Install More Packs

If more than 4 packs need to be installed, divide them into two columns of which has no more than four packs for each column.

Step 1: Using tandem optional kit **P** to replace Control Box and Mounting Base.

Step 2: Cut the holes in the bottom with a knife and connect power and communication cable correctly.

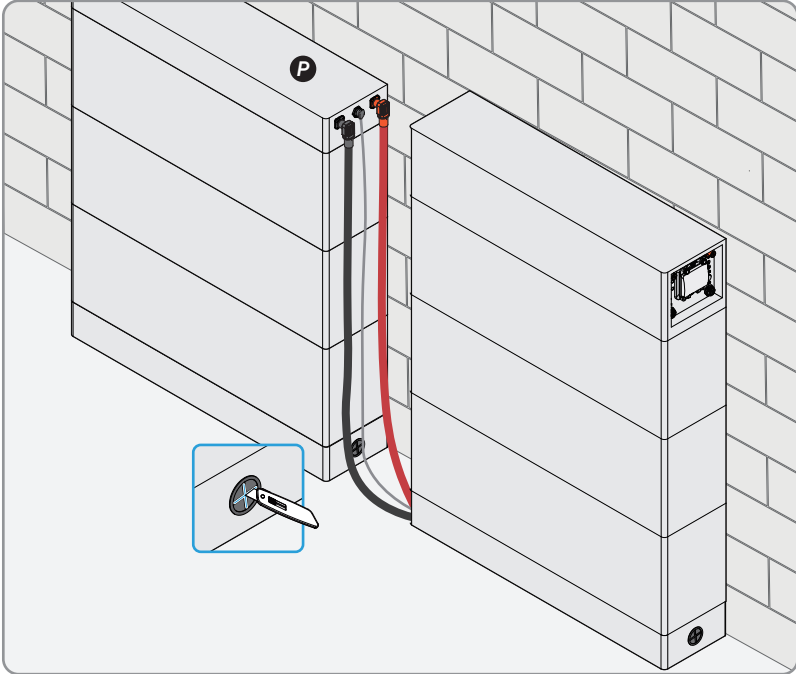

Figure 5-6 Installing More Packs

6 Electrical Connection

⚠ QUALIFIED PERSON





6.1 Battery Connection

Before connecting the power cables, please make sure the DC breaker of the battery is disconnected.

Step 1: Install the Quick-Plugs of power cable to the battery.

Step 2: Install the OT terminals ends of grounding cable to the grounding point of the battery, then connect it the grounding point of inverter.

Step 3: Plug the other ends of power cables into inverter.

-  Positive Power Cable
-  Negative Power Cable
-  COM Communication Cable
-  PE Cable

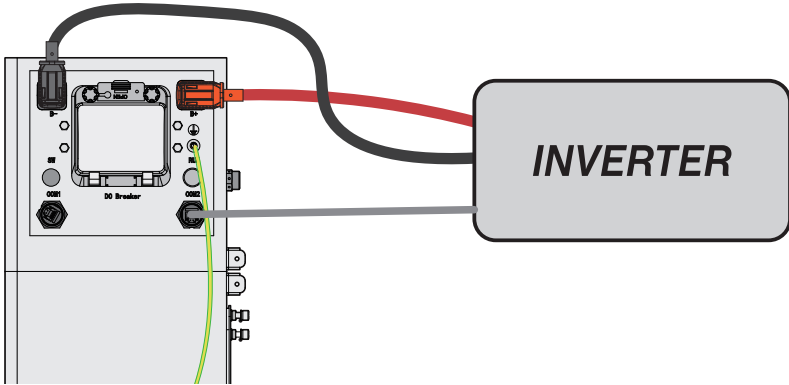

Figure 6-1 Battery Connection

6.2 BMS Communication Connection

Please check whether the communication cable in the accessory box is appropriate for the battery. If you are not sure for that, please confirm with your vendor.

Step 1: Please insert the connector of the communication cable into the BMS Communication COM2 port of battery.

Step 2: Please insert the other end of the cable in the corresponding port of inverter.

Table 6-1 BMS Connector Pin Definition

BMS Connector Pin Definition		
	1	BMS_CAN_H
	2	BMS_CAN_L
	3	Reserved
	4	Reserved
	5	Reserved
	6	Reserved
	7	Reserved
	8	Reserved

7

Operation

⚠ QUALIFIED PERSON

7.1 LED Indicator

Table 7-1 Indicator Description

Status Light	Description
Green	Green light indicates the battery works well.
Red	Fault occurs in the battery. SOC \leq 8%



NOTE

When red light is on for more than 6 hours indicates fault occurs in the battery, please contact technical support for help.

7.2 Turn On/Off the Battery

- When turn it on the battery and connect the DC breaker;
- When turn it off the battery, disconnect the DC breaker.
- Check the following items before starting the battery:
 - Check the battery system has been installed completely.
 - Check the appearance of the battery system is intact.
 - Check the battery system output wiring harness is correctly connected to the positive and negative terminals of the battery and inverter to avoid misconnection and reverse connection.

7.3 Commissioning Procedure

Manually connect the DC breaker of all the batteries, then switch all the batteries on. Then BMS will enter the self-test state. Wait until the indicator is steady on in green, which indicates that the battery system is powered on and runs normally.

7.4 Decommission

Decommission the battery in the system after the inverter is decommissioned. Proceed as follows to decommission the battery.

- Manually disconnect the DC breaker of all the batteries.
- One minute after the DC breaker is disconnected, disconnect all cables between the battery and other devices.

8

Technical Specifications

Model	BHF-S10	BHF-S15	BHF-S20	BHF-S25	BHF-G30
Nominal Voltage [V]	204.8	307.2	409.6	512	614.4
Operating Voltage Range [V]	172.8 - 230.4	259.2 - 345.6	345.6 - 460.8	432 - 576	518.4 - 691.2
Battery Module	102.4 V 50 Ah 512 kW				
Number of Modules	2	3	4	5	6
Total Energy [kWh]	10.2	15.4	20.5	25.6	30.7
Usable Energy [kWh]	9.2	13.8	18.4	23.0	27.6
Rated Capacity [Ah]	50				
Nominal Power [kW]	5.1	7.7	10.2	12.8	15.4
Max. Power [kW]	9.8	14.7	19.7	24.6	29.5
Rated Charge/Discharge Current [A]	25				
Max. Charge/Discharge Current [A]	48				
Operating Temperature (Charging/Discharging) [°C]	0 - 55 / -20 - 55				
Storage Temperature [°C]	-20 - 55				
Operating Humidity	5% - 95%				
Operating Altitude [m]	<4000				
Installation Location	Wall-mounted / Ground-mounted				
Battery to Inverter Communication	CAN				
Battery to Battery/BMS	CAN				
Ingress Protection	IP65				
Cycle Life	6000 Cycles ^[1]				
Certificate	CE, UN38.3, IEC62619, IEC610				
Dimensions (W × H × D) [mm]	870 × 878.5 × 208.7	870 × 1167 × 208.7	870 × 1455 × 208.7	870 × 1167 × 208.7 870 × 778 × 208.7	870 × 1167 × 208.7 870 × 1067 × 208.7
Weight [kg]	147	209	271	147+209=356	209+209=418

[1]: Test conditions: 0.5C Charge/0.5C Discharge, @25 °C 90% DOD, 70% EOL.

LIVOLTEK



Power Your Life with Green Energy

 www.livolttek.com

 info@livolttek.com

 1418-35, Moganshan Road, Hangzhou, 310011, China